

# SL1+

## Quick Installation Guide

Premise unit location and wiring methods shall be in accordance with the National Electrical Code, ANSI / NFPA 70-1987.

**WARNING:** Installation of other equipment or devices within the SL1+, or powering of non-approved equipment or devices from the SL1+, may cause system failure or damage, may void all warranties, and may void the UL Listing.

### Specifications

SL1+ POWER SUPPLY - Do not connect to a receptacle controlled by a switch.

INPUT - 115 V AC 60 Hz, 1 A  
OUTPUT - 24 V AC, 56 VA

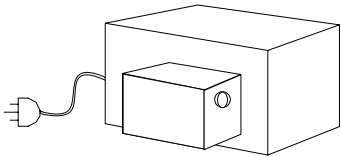

STANDBY BATTERY PACK - 24 V , 1.2 AH  
UPS load test should be performed at least once per year. With the primary AC fuse removed for 5 minutes, the system must function normally while powered only by the standby batteries.

FUSES - All fuses are 5mm x 20mm, 250V, Time-Delay (Slo-Blo).

Power Supply	1 A
F1 Keypad Power	1 A
F2 24 V AC Power	2 A
F3 SYS BAT Power	2 A
F4 SYS BAT Charge	0.5 A

MFG: \_\_\_\_\_  
(date)

Request-to-Exit devices.  
Normally Open contact.  
Cable is 22 gauge twisted shielded pair.

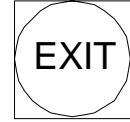

SCRAMBLEPAD® connection.  
Maximum 2 keypads. Refer to ScramblePad Installation Guide.

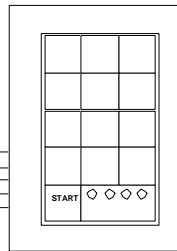

UL Note:  
Keypad annunciates continuously when box TAMPER is active. Keypad stops announcement after SL1+ door has been closed 15 seconds.

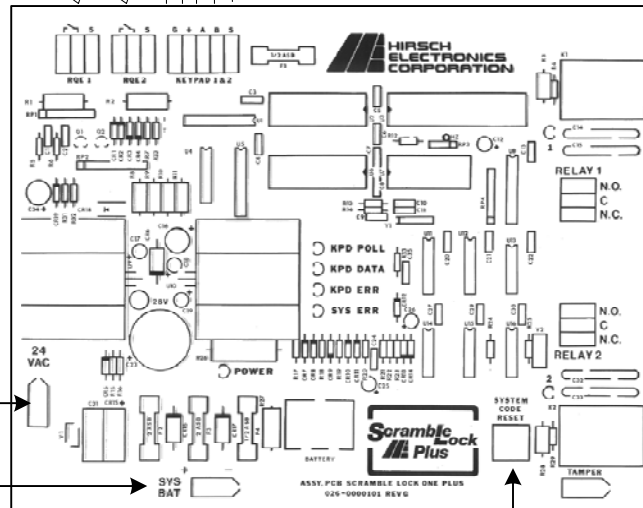

SYSTEM CODE RESET PUSHBUTTON	
1 Second	Resets any actuated relay
5 seconds	Resets system security code to factory default 123
30 seconds	Resets system. Clears all memory.

SYSTEM STATUS LEDS	
POWER	On with AC or DC power
KPD POLL	Flash indicates system polling keypads
KPD DATA	Flash indicates keypad poll response
KPD ERR	Flash on keypad data errors
SYS ERR	On steady for system failure.
RELAY 1,2	On while relay is actuated.

SCRAMBLEPAD Cable - 2 twisted shielded pair.  
4-conductor twisted shielded acceptable.

AWG	DS37L	DS37L-HI	2 DS37L	DS37L + DS37L-HI	2 DS37L-HI
22	750'	450'	375'	275'	225'
18	1850'	1150'	925'	700'	575'

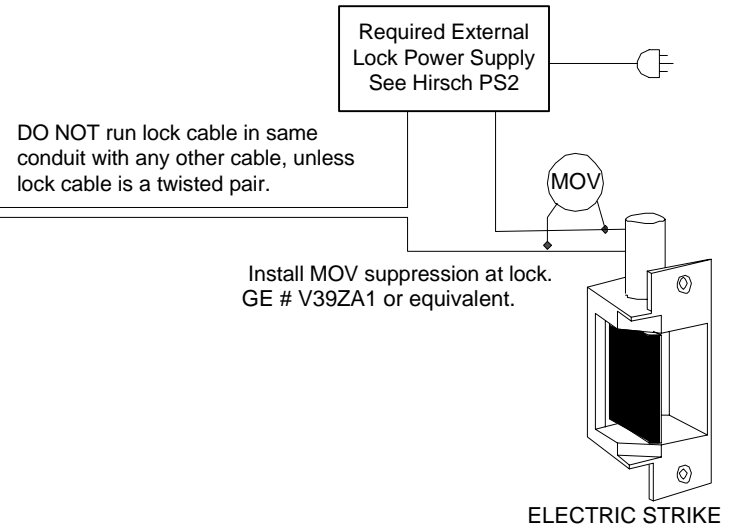

Install MOV suppression at lock.  
GE # V39ZA1 or equivalent.

### LOCK POWER CABLE - DISTANCE VS WIRE GAUGE CALCULATION

The maximum distance for the lock power cable is a function of wire gauge and lock current:

$$\text{DISTANCE (feet)} = \frac{\text{WGV}}{\text{Lock Inrush Current}}$$

1. Choose the wire gauge, and use the "WGV" value from the following table:

Wire Gauge	22	20	18	16	14	12
WGV	123	198	312	500	794	1258

2. Determine lock inrush current. Always calculate cable distance based on lock inrush current, NOT on lock holding current. Unless otherwise specified:

$$\text{Lock Inrush Current} = \frac{\text{Lock Voltage}}{\text{Lock Coil Ohms}}$$

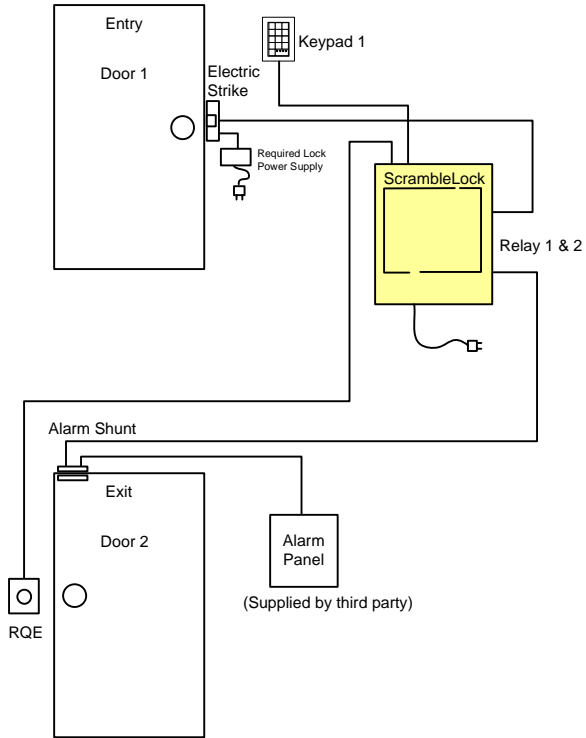

**One-Door System**

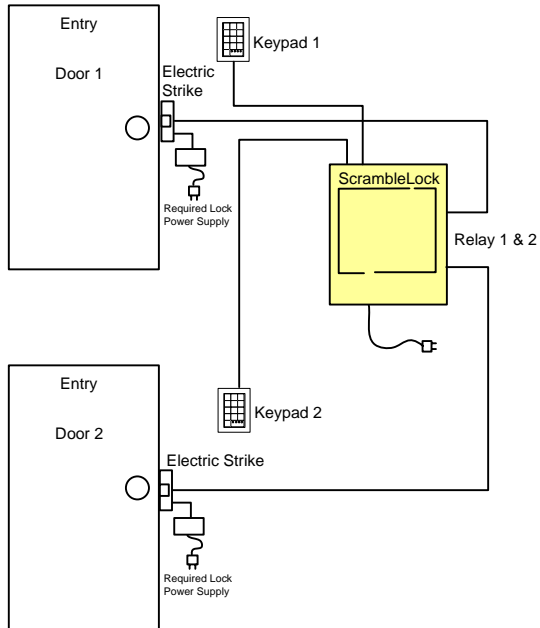

**Two-Door System**

**Specifications**

System Power	115 VAC 60 Hz, 15A circuit 230 VAC 50 Hz
Controller Power	24 VAC, 56VA internal transformer
Standby Power	24V, 1.2Ah Gel Cell Battery Pack
Keypad Power Output	28VDC, sufficient for 2 DS37L/DS47L keypads
Keypad Compatibility	DS37L/DS47L
Relay Contact Rating	10A @ 240VAC/28VDC Dry contacts – no power
Data A&B Interface	Hirsch Enhanced Serial
Temperature	32° to 120° F (0° to 49° C)
Relative Humidity	0% to 90% non-condensing
Size	12 x 12 x 4 inches
Shipping Weight/ Shipping Size	16.1 lbs. 19 x 13¼ x 5¼ inches
Standard Documentation	Installation Notes and Programming Guide
Warranty	One year

SL1P-IN2-2005

Hirsch Electronics  
1900 Carnegie Ave., Building B  
Santa Ana, CA 92705  
(949) 250-8888

# SL1+ ScrambleLock

## Installation Guide

