

Firmware Reflashing	
P1 ● ○ P2 ○ ○	Receiving CCM reflash image. When complete, the CCM reflashes and the SNIB2 shows the SNIB2/CCM Synchronization pattern. (While the CCM reflashes itself, the controller's red and green AC LEDs are both lit on the motherboard.)
P1 ② ○ P2 * ●	If several units connected to the same master have their CCMs reflashed simultaneously, the reflashing will take some time and the LEDs may look like this while the process is ongoing.
P1 * ○ P2 ○ ○	Currently receiving the SNIB2 reflash image. When complete, the SNIB2 signals this by showing the pattern below:
P1 ○ ○ P1 ○ ○ P1 ● ● P1 ○ ○ P1 ○ ○ P1 ○ ○ P1 ● ● P2 ○ ○ P2 ● ● P2 ○ ○ P2 ○ ○ P2 ○ ○ P2 ● ● P2 ○ ○ P3 ● ● P3 ○ ○ P3 ○ ○ P3 ○ ○ P3 ● ● P3 ○ ○ P3 ○ ○	
The SNIB2 is erasing and reprogramming its firmware in flash memory, using the image that the Velocity Server has just downloaded to it. The controller associated with this SNIB2 will be offline until this process completes; if this is the master SNIB2, the entire loop will be offline until the reprogramming is completed. When the SNIB2 is finished, you will see the Lamp Test pattern followed in quick succession by the SNIB2/CCM Synchronization pattern.	

Data Transmission Trouble (Normally seen on Master SNIB2)	
P1 ○ *	RS-485 parity error. An occasional blink is not a problem; however, persistent parity errors can lead to symptoms like offline controllers or 'Unknown Controller Online' messages.
P1 ○ * P2 * *	Downstream communication with errors.
P1 ○ * P2 ○ ○ or P1 ○ * P2 ○ *	Bad data on RS-485 line.
P1 ○ * P2 * ○	Hunt poll with data I/O errors.
P1 ○ ○ P2 * ○	Cannot communicate with downstream controllers.
P1 ○ * P2 * *	
P1 ○ * P2 * ○	Cannot communicate with downstream controllers.
P1 ○ * P2 * ○	

For more information on setting up this SNIB2, refer to the *SNIB2 Quick Install Guide* and the *SNIB2 Configuration Supplement (SUPP09)*.

1900 Carnegie Ave. Bldg. B
Santa Ana, CA 92705-5520
(949) 250-8888
www.hirschelectronics.com

Diagnostic LEDs

These LEDs represent:

P1	● ●	Green = firmware download Yellow (rev. D)/Red (rev. C) = data trouble
P2	● ●	RS-485 communication
P3	● ●	Host communication

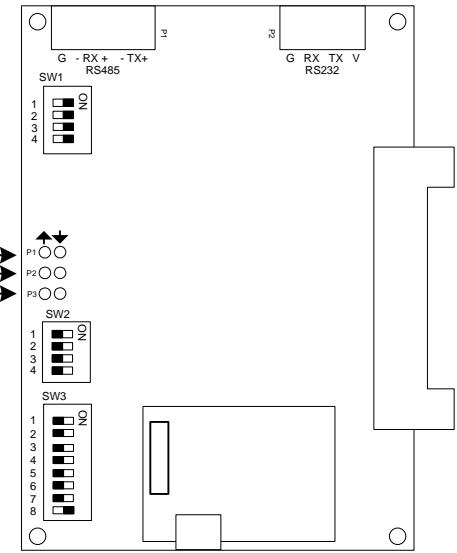

RJ-45 Jack LEDs *
(see box at bottom)

SNIB2 Network Example:

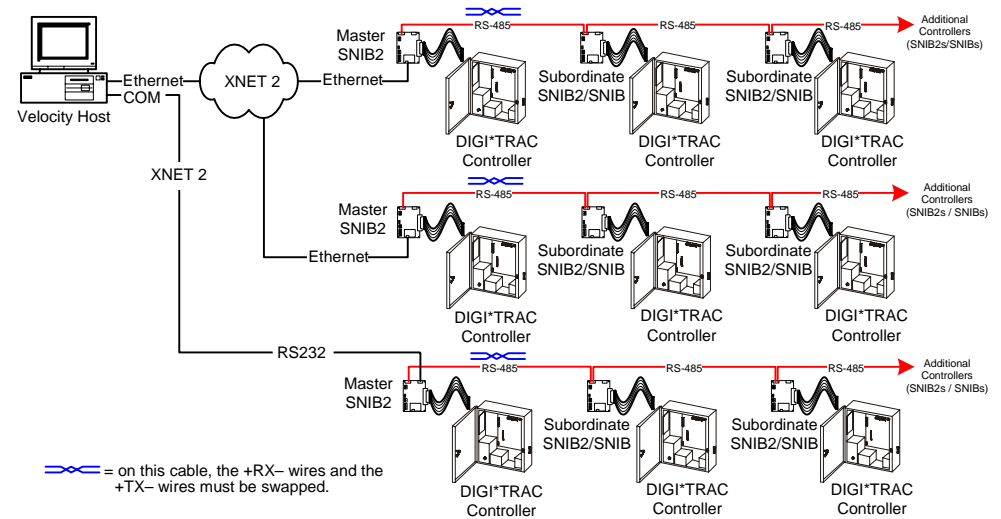

* The tiny green and yellow LEDs directly next to the RJ-45 jack on the daughterboard indicate the presence of an Ethernet network and network activity.

- 1 green LED = 10BaseT
- 2 green LEDs = 100BaseT
- Yellow flashing = any activity on the net

If you connect the SNIB2 to your LAN on the same subnet as your computer, checking your e-mail or browsing a web page should cause the green LEDs to light and the yellow LED to flash.

Normal Operation (Master or Subordinate)	
P1 ○ ○ P2 ⊕ ⊕	Ordinary communication between master and subordinates. Lights may blink or stay lit during heavy data transfers. They will go out every 4 seconds during idle or low-traffic periods; this is normal, indicating the master is hunting for new addresses, such as newly-added controllers or controllers that went offline and are expected back online.

Normal Operation (Master)	
P1 ○ ○ P2 ● ● P3 ● ●	This could be programming activity (downloads) or events, or both.
P1 ○ ○ P2 ● ✱ P3 ● ●	P2's red LED flashes while P2 green and P3 red and green stays lit. This normally means that the Velocity server is in the process of downloading CCM or SNIB2 firmware to one or more controllers.
P3 ✱ ✱	Heartbeat. If the P3 LED flashes appear to be about 5 seconds apart, it means the host is keeping the communication link open.

Normal Operation (Subordinate)	
P1 ○ ○ P2 ○ ✱ P3 ○ ○	The master is polling a different SNIB2. This SNIB2 ignores those polls.
P1 ○ ○ P2 ○ ● P3 ○ ○	If this stays lit and doesn't go out every 4 seconds, that means there's a lot of data going to or coming from some other controller(s). If you don't see any green flashes at all, this unit won't come online until the data traffic decreases. This pattern may also alternate with occasional red or green P3 flashes.
P1 ○ ○ P2 ✱ ● P3 ○ ○	If these stay flashing and lit, it means there is a lot of data going to or coming from several controllers. This occurs particularly when you have many controllers.
P1 ○ ○ P2 ● ● P3 ○ ○	If these stay lit, it means there is a lot of data going to or coming from this particular controller.

Legend:	○ = LED OFF	● = LED ON	Ⓜ = Lit for 2 Seconds
	⊕ = LED Flashing or ON	✱ = LED Flashing	↔ = Alternating with

Special Light Patterns: Start Up													
P1 ● ● P1 ○ ○ P2 ● ● P2 ○ ○ P3 ● ● P3 ○ ○	<table border="1"> <tr> <td>P1 ● ●</td> <td>P1 ○ ○</td> <td>P1 ○ ○</td> <td>P1 ○ ○</td> </tr> <tr> <td>P2 ● ●</td> <td>P2 ● ●</td> <td>P2 ○ ○</td> <td>P2 ○ ○</td> </tr> <tr> <td>P3 ● ●</td> <td>P3 ● ●</td> <td>P3 ● ●</td> <td>P3 ○ ○</td> </tr> </table> <p>Lamp Test. Power-up might include the first two patterns. If you've just reflashed the SNIB2, the sequence starts with the ones in the box. Followed by:</p>	P1 ● ●	P1 ○ ○	P1 ○ ○	P1 ○ ○	P2 ● ●	P2 ● ●	P2 ○ ○	P2 ○ ○	P3 ● ●	P3 ● ●	P3 ● ●	P3 ○ ○
P1 ● ●	P1 ○ ○	P1 ○ ○	P1 ○ ○										
P2 ● ●	P2 ● ●	P2 ○ ○	P2 ○ ○										
P3 ● ●	P3 ● ●	P3 ● ●	P3 ○ ○										
P1 ○ ● P1 ○ ○ P1 ○ ○ P1 ○ ○ P1 ○ ○ P1 ● ○ P1 ○ ● P2 ○ ○ P2 ○ ● P2 ○ ○ P2 ○ ○ P2 ● ○ P2 ○ ○ P2 ○ ○ P3 ○ ○ P3 ○ ○ P3 ○ ● P3 ● ○ P3 ○ ○ P3 ○ ○ P3 ○ ○	SNIB2/CCM Synchronization. Repeats until the CCM and SNIB2 are synchronized. This light pattern should not persist longer than four minutes if there are no memory expansion boards on the controller.												

Special Light Patterns (Master)	
P1 ● ○ P1 ○ ● ↔ P3 ● ○ P3 ○ ●	The SNIB2 keys are at factory default. No IP address is set. There is no communication with Velocity. In v.5.95 and later, this pattern is no longer applicable.
P1 ● ○ P1 ○ ● ↔ P3 ○ ○ P3 ○ ○	The SNIB2 keys are at factory default. There is an IP address set. There is no communication with Velocity. You may need to Reset Encryption on the Velocity port.
P3 Ⓜ ○	Port Search. Velocity is searching for SNIB2s. (Ethernet only)
P3 ○ Ⓜ	Velocity has just configured this unit. (Ethernet only)

Special Light Patterns (Subordinate)	
P1 ● ○ P1 ○ ● ↔ P3 ● ○ P3 ○ ●	This unit has synchronized this SNIB2 and its CCM, but the master SNIB2 has not yet detected it. For newly added or rebooted units, this means the master is busy with other controllers on the same loop, especially if the P2 red LED is lit.
or	
P1 ● ○ P1 ○ ● ↔ P3 ○ ○ P3 ○ ○	You can also see this pattern if the master SNIB2 has just been reflashed and has not yet completed initialization.

Legend:	○ = LED OFF	● = LED ON	Ⓜ = Lit for 2 Seconds
	⊕ = LED Flashing or ON	✱ = LED Flashing	↔ = Alternating with