

### Network Address Settings (S3 - S8)

Addr	S3	S4	S5	S6	S7	S8	Addr	S3	S4	S5	S6	S7	S8
1	OFF	OFF	OFF	OFF	OFF	ON	33	ON	OFF	OFF	OFF	OFF	ON
2	OFF	OFF	OFF	OFF	ON	OFF	34	ON	OFF	OFF	OFF	ON	OFF
3	OFF	OFF	OFF	OFF	ON	ON	35	ON	OFF	OFF	OFF	ON	ON
4	OFF	OFF	OFF	ON	OFF	OFF	36	ON	OFF	OFF	ON	OFF	OFF
5	OFF	OFF	OFF	ON	OFF	ON	37	ON	OFF	OFF	ON	OFF	ON
6	OFF	OFF	OFF	ON	ON	OFF	38	ON	OFF	OFF	ON	ON	OFF
7	OFF	OFF	OFF	ON	ON	ON	39	ON	OFF	OFF	ON	ON	ON
8	OFF	OFF	ON	OFF	OFF	OFF	40	ON	OFF	ON	OFF	OFF	OFF
9	OFF	OFF	ON	OFF	OFF	ON	41	ON	OFF	ON	OFF	OFF	ON
10	OFF	OFF	ON	OFF	ON	OFF	42	ON	OFF	ON	OFF	ON	OFF
11	OFF	OFF	ON	OFF	ON	ON	43	ON	OFF	ON	OFF	ON	ON
12	OFF	OFF	ON	ON	OFF	OFF	44	ON	OFF	ON	ON	OFF	OFF
13	OFF	OFF	ON	ON	OFF	ON	45	ON	OFF	ON	ON	OFF	ON
14	OFF	OFF	ON	ON	ON	OFF	46	ON	OFF	ON	ON	ON	OFF
15	OFF	OFF	ON	ON	ON	ON	47	ON	OFF	ON	ON	ON	ON
16	OFF	ON	OFF	OFF	OFF	OFF	48	ON	ON	OFF	OFF	OFF	OFF
17	OFF	ON	OFF	OFF	OFF	ON	49	ON	ON	OFF	OFF	OFF	ON
18	OFF	ON	OFF	OFF	ON	OFF	50	ON	ON	OFF	OFF	ON	OFF
19	OFF	ON	OFF	OFF	ON	ON	51	ON	ON	OFF	OFF	ON	ON
20	OFF	ON	OFF	ON	OFF	OFF	52	ON	ON	OFF	ON	OFF	OFF
21	OFF	ON	OFF	ON	OFF	ON	53	ON	ON	OFF	ON	OFF	ON
22	OFF	ON	OFF	ON	ON	OFF	54	ON	ON	OFF	ON	ON	OFF
23	OFF	ON	OFF	ON	ON	ON	55	ON	ON	OFF	ON	ON	ON
24	OFF	ON	ON	OFF	OFF	OFF	56	ON	ON	ON	OFF	OFF	OFF
25	OFF	ON	ON	OFF	OFF	ON	57	ON	ON	ON	OFF	OFF	ON
26	OFF	ON	ON	OFF	ON	OFF	58	ON	ON	ON	OFF	ON	OFF
27	OFF	ON	ON	OFF	ON	ON	59	ON	ON	ON	OFF	ON	ON
28	OFF	ON	ON	ON	OFF	OFF	60	ON	ON	ON	ON	OFF	OFF
29	OFF	ON	ON	ON	OFF	ON	61	ON	ON	ON	ON	OFF	ON
30	OFF	ON	ON	ON	ON	OFF	62	ON	ON	ON	ON	ON	OFF
31	OFF	ON	ON	ON	ON	ON	63	ON	ON	ON	ON	ON	ON
32	ON	OFF	OFF	OFF	OFF	OFF							

Installations with NET\*MUX4s support up to 63 controllers. Installations without NET\*MUX4s are limited to 16 controllers, which can have any address in the range 1-63. Where possible, limit your multi-drops to 16 units for optimum speed and performance. Even at 9600 bps, two 16-unit configurations outperform one 32-unit configuration.

**For more information on setting up this SNIB2, refer to the SNIB2 Troubleshooting Guide and the SNIB2 Configuration Supplement (SUPP09).**



1900 Carnegie Ave. Bldg. B  
Santa Ana, CA 92705-5520  
(949) 250-8888  
www.hirschelectronics.com

# HIRSCH ELECTRONICS SNIB2 Quick Installation Guide

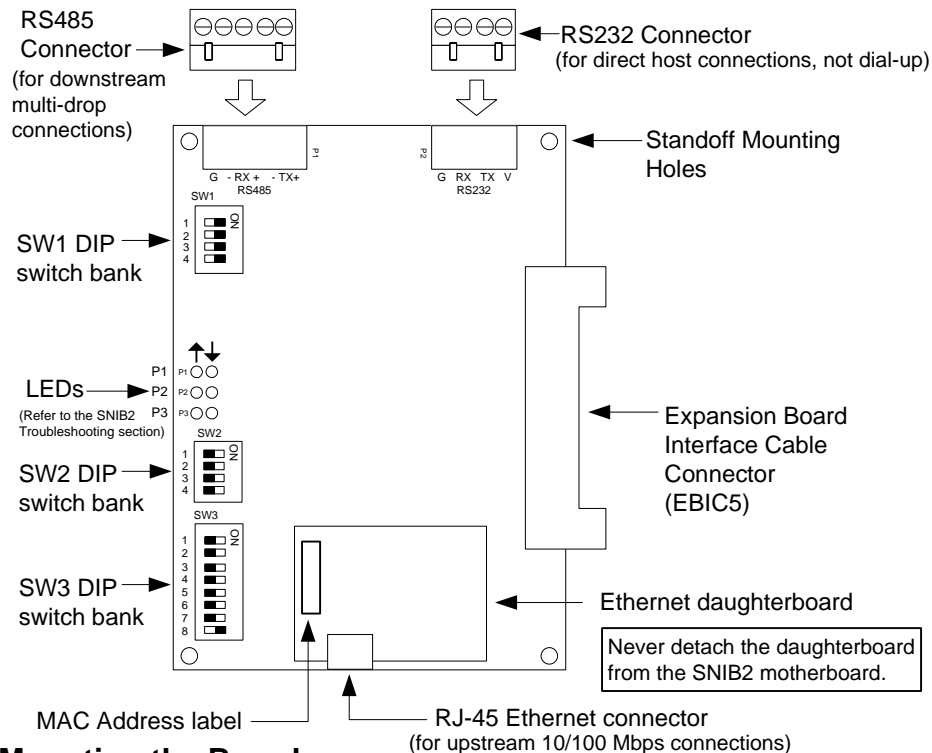

## Mounting the Board

To mount the SNIB2 expansion board:

1. Turn all system power off: remove the connector for the standby battery, disconnect the AC power connector or the power supply fuse.
2. Install the new SNIB2 board into the upper left corner of the enclosure using the supplied screws. If there are additional expansion boards to install, install them first using the supplied standoffs. Install the SNIB2 board last so that it is at the top of the stack.
3. Connect the EBIC5 connector. Reconnect the AC power connector (or power supply fuse), then reconnect the standby battery connector. The controller board's yellow test LED should light; the other lights go through a start up sequence. When the sequence is complete, the yellow test LED goes out and the other lights stabilize.
4. If required, connect an RJ-45 network cable to the SNIB2 Ethernet connector.

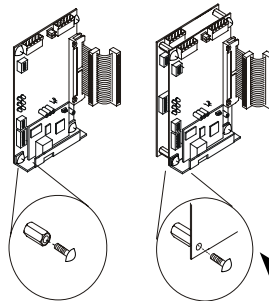

**! If a MEB/BE, MEB/CE, or MEB/CB board is installed, do not remove it. Removing any of these boards will cause the controller to malfunction and requires a system cold start. This will erase all additional information in their memory and requires complete system download.**

If you stack boards, make sure the SNIB2 is on top of the stack  
Connect screws to the board

## Wiring the Board

To connect RS-485 serial cables between SNIB2s:

1. Turn all system power off by first removing the connector for the standby battery, then disconnect the AC power connector or the power supply fuse.
2. Punch out the knockout in the controller enclosure where you plan to route the RS-485 cable. You can either route this wire through the same opening you're using for controller board connections, or knock out a new opening.
3. Route the wires through the opening. If it makes serial wiring easier, detach each green connector from the board as needed.
4. Loosen the screws until the wire is securely fastened in the slot.
5. Remove insulation from the wire and insert the specified wires into the green connectors at the required slots as shown to the right.
6. Tighten the screws until the wire is securely fastened in the slot.
7. If you removed the green connector in step 3, push the green connector into the appropriate socket until it locks into place. The connector and socket are keyed, so there is only one way to plug it in.
8. Reconnect the system power by first connecting the AC power connector, then connecting the standby battery connector.

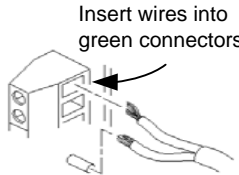

If you plan to multidrop SNIBs/SNIB2s, the cable between the first (Master) controller and the second must be wired as shown here:

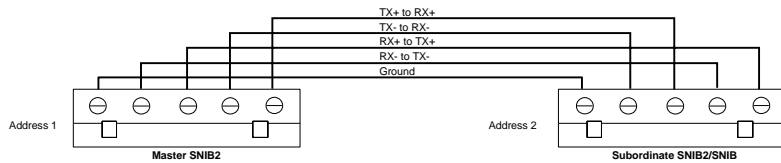

Subsequent controllers on the same chain are wired point-to-point.

Communications become less robust as baud rates increase, wire gauge decreases, and distances increase. Most tables in the *DIGI\*TRAC Design and Installation Guide* for wire gauge and distance are based on 9600 baud. At higher baud rates, maximum distances are decreased and minimum wire gauge is increased. It may not be possible to implement the higher baud rates supported by the SNIB2 if you have long wire runs or small wire gauges. Higher baud rates are also more dependent on the number of twists per foot, so capacitance specifications must be strictly followed: total wire run per port is not to exceed 100,000 pf per foot.

### Standard Cable

SNIB2 RS-485 installations with standard 18-, 20-, and 22-gauge shielded twisted-pair cable should use 9600 or 38400 bps. Do not use higher speeds. If you have communication problems at 38400 bps, reduce it to 9600 bps. Installations with NET\*MUX4s are limited to 9600 bps.

### Cat5 Cable

For new SNIB2-to-SNIB2 RS-485 installations, we recommend making your cables with Cat5 or equivalent grade cable to the appropriate 5-pin green connectors. Pick one color wire, such as brown, to use for Ground. Distances up to 4000 feet can be achieved with this RS-485 cabling type. If there is no NET\*MUX4 involved, you can use 57600 or 115200 bps.

**In order to use the SNIB2, your controller must include CCM Vn. 7.3.08 or higher. Use Vn. 7.4.02 or higher if your computer has Velocity 3.0.**

## Setting Up the Board

Before you can install the SNIB2, you must first set the required DIP switches on the three switch banks as shown below:

Switch Bank 1 (SW1)		
S1 - 4	OFF	This SNIB2 is in the middle of a multidrop sequence.
	ON	This SNIB2 is either first (master) or last (termination) in the multidrop sequence.

Switch Bank 2 (SW2)		
S1	OFF	The SNIB2 communicates with the host PC in XNET 2 using the encryption keys stored in memory.
	ON	Return the encryption keys to their default settings. If this switch is set when the SNIB2 powers up or reboots after a firmware upgrade, the keys reset. This switch can be turned off after the LED patterns begin to light. See <i>SNIB2 Troubleshooting Guide</i> . If this is the master SNIB2, you must also 'Reset Encryption' on the Velocity Port settings. All downstream units must have their encryption keys reset as well. If this is a downstream unit, the master SNIB2 automatically detects that the keys have been reset.
S2-3	OFF	Reserved.
S4	OFF	This SNIB2 is NOT first in the multidrop sequence, or you only have one controller.
	ON	This SNIB2 is first in the sequence (master) and is connected to the host via Ethernet or direct RS-232 connection (not dial-up). This SNIB2 controls polling.

Switch Bank 3 (SW3)					
S1	OFF	OFF	ON	ON	
S2	OFF	ON	OFF	ON	
bps	9600	38400	57600	115200	

This controls the baud rate for the RS-485 multi-drop line and the RS-232 connection. 57600 and 115200 bps are only available if your RS-485 cables are made from Cat5/Cat6 data grade wire. These speeds are not recommended for installations using:

- RS-232 connections to host
- 18- to 22-gauge shielded twisted-pair cable
- NET\*MUX4s
- Mixed SNIBs/SNIB2s

Baud rates only apply to the SNIB2's RS-485 and RS-232 ports. The SNIB2's Ethernet port is used for host-to-controller connections and runs at 10/100 BaseT speeds. All SNIBs/SNIB2s in an RS-485 multi-drop sequence must be set to the same speed, and if connected to a host PC using RS-232 direct connection, the same speed must also be used. For example, if one SNIB2 in the sequence is set to 9600, all other SNIBs and SNIB2s (and the RS-232 host connection, if used) must be set to the same baud rate.

### CCM and SNIB2 Firmware Upgrade Path:

- Upgrade CCM firmware and physically replace a SNIB with a SNIB2: Upgrade CCM first, then switch the SNIB for the SNIB2.
- Upgrade the CCM firmware and either physically replace a SNIB2 with another SNIB2 OR upgrade SNIB2 firmware: It doesn't matter which you upgrade first.

### Firmware Downloads:

- Do not download CCM and SNIB2 firmware simultaneously on the same port.
- Do not download CCM or SNIB2 firmware to the master SNIB2 at the same time as downstream units on the same port. We recommend upgrading the master before upgrading downstream units.
- Do not download firmware to more than two downstream CCMs or three downstream SNIB2s on the same port at the same time. The firmware download time multiplies with each additional controller downloading.